



THANK YOU FOR CHOOSING ANOTHER WAY!

In the interests of your safety and proper use of the product,
please read this manual before using RAPTORS PEDALS.

THANK YOU!

Contents

1. Warning.....	5
2. Notes	6
3. Pedal dimensions.....	8
4. Pedal adjustment.....	10
4.1 Changing the position of the stopper.....	10
4.2 Changing the angle of the pedal lever	11
4.3 Changing the position of the compression spring...	13
4.4 Compression spring adjustment with knurled knob	14
4.5 Changing the position of the pedal foot	15
4.6 Changing elastomers in the brake pedal.....	16
5. Pedal characteristics	17
6. Electronics connection.....	19
7. Calibration.....	20
8. Maintenance	25
9. Environmental recommendations	26
10. Warranty information	26

CONTACT US:



+48 607 587 509
+48 665 140 498



kontakt@aw-anotherway.pl



VIA THE CONTACT FORM:

<https://aw-anotherway.pl/support>



1. **Warning**

To ensure complete safety for yourself and others when using RAPTORS PEDALS, follow the guidelines below:

- ✓ NEVER play the pedal set without proper footwear. It is FORBIDDEN to play barefoot or in socks, flip-flops, etc.;
- ✓ NEVER use pedals that are not properly and permanently attached;
- ✓ RAPTORS PEDAL SET is not intended for children under 15 years of age;
- ✓ The product contains small parts that may cause choking if swallowed, as well as injuries, and even death in small children. Be especially careful when handling small parts and keep them away from children;
- ✓ Only connect the product to certified computers;
- ✓ The USB cable and plug must not have any signs of destruction, damage, breakage of the cable sheath and damage to the plug;
- ✓ Unplug the product if it will not be used for a long time;
- ✓ DO NOT modify the product, contact the manufacturer in case of malfunction;
- ✓ DO NOT attempt to repair the product.

2. Notes

Remember that you or the person(s) accompanying you should never put their fingers or other parts of their body in the following places while playing RAPTORS PEDALS:

- ✓ to the sides of the pedals;
- ✓ to the back of the pedals;
- ✓ to the front surface of the pedal lever;
- ✓ and wherever there is a possibility of cutting and/or personal injury.

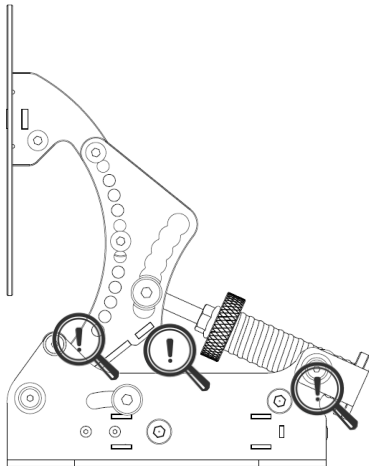

fig.1 Sensitive places in the pedals, where it is forbidden to insert fingers and other body parts.

The product is completely safe when used for the purposes for which it was created. All other unforeseen uses are inadvisable and prohibited.

**ANOTHER WAY SHALL NOT BE RESPONSIBLE
FOR ANY INJURY THAT COULD RESULT FROM
IMPROPER USE OF THE PEDALS. PROTECT
YOUR HEALTH - FOLLOW THE
RECOMMENDATIONS!**

3. Pedal dimensions

Figures [fig. 2,3,4] show the dimensions of all pedals, dimensions are shown in [mm].

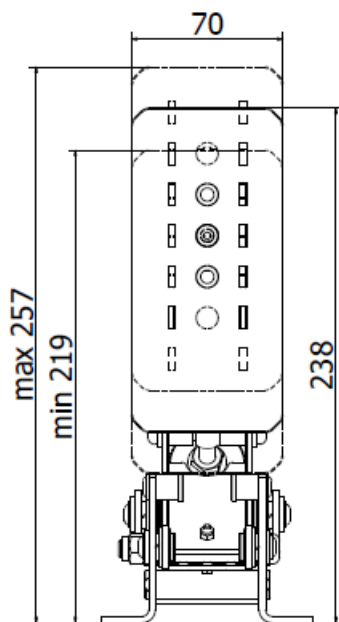

fig. 2 Height.

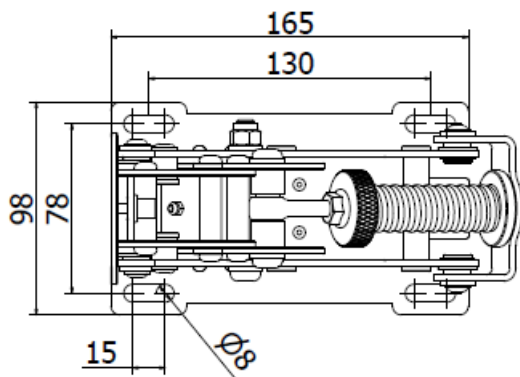

fig. 3 Width including mounting holes.

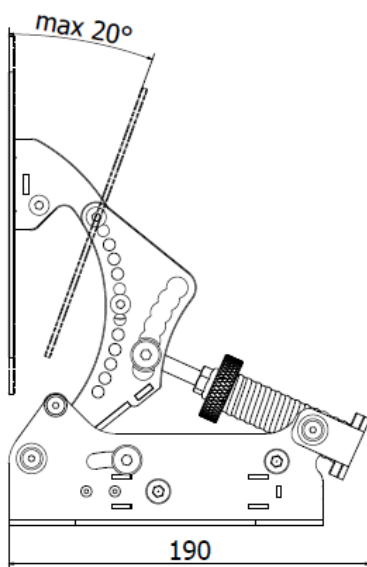

fig. 4 Length including the maximum angle of deflection of the pedal lever.

4. Pedal adjustment

4.1 Changing the position of the stopper

To change the working range of the pedal lever with the stopper, loosen the nut using a 13 spanner and an H5 Allen key. Then move the screw with the stopper to the desired place, and then tighten the nut.

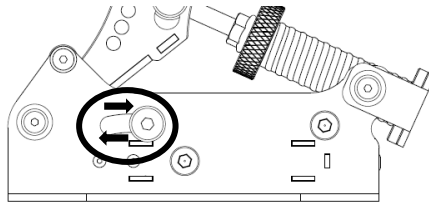

fig. 5 Directions and scope of change

As a result of changes in the position of the stopper (depending on the selected position), we can obtain a maximum deflection in the range from 10° to 20° .

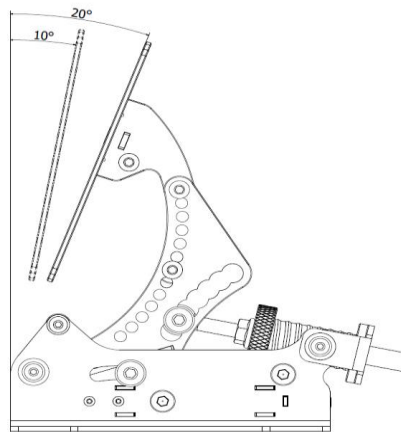

fig. 6 Range of maximum pedal lever deflection.

4.2 Changing the angle of the pedal lever

When proceeding to change the angle of the lever, it is necessary to:

1. loosen the screws securing the spring mechanism sleeve using H5 Allen keys;

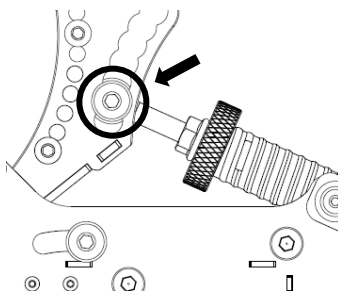

fig. 7 The first stage of changing the angle of the pedal lever.

2. unscrew all four screws on the pedal lever with an H4 Allen key.

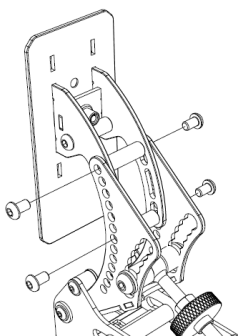

fig. 8 The second stage of change.

3. move the lever with positioning sleeves to the preferred position, and then screw it with four mounting screws so that there is no play.

ATTENTION!

Remember to place the positioning sleeves in the extreme positions after selecting the preferred position (fig. 9.1).

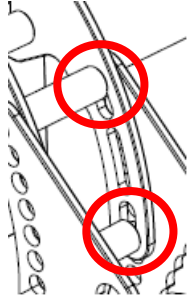

fig.9.1 Extreme mounting positions

4. tighten the screws securing the sleeve of the spring mechanism using H5 Allen keys (see Fig. 7).

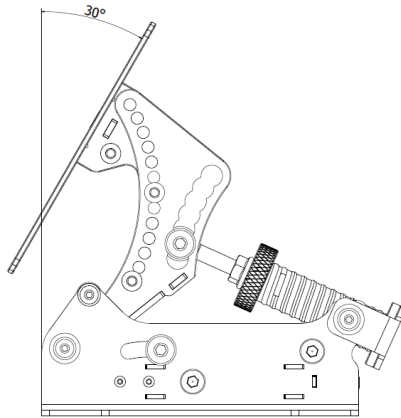

fig. 9.2 The third stage of change.

Fig. 9.2 shows the maximum lever deflection of 30°

4.3 Changing the position of the compression spring

To ensure a comprehensive range of adjustment, a seven-step range of changing the position of the compression spring has been designed. This translates into a wide range of combinations of spring settings and force adjustment to individual needs. The spring fixed at the highest point of the seven-point scale is characterized by the greatest resistance force, while set in the lowest hole it presents the lowest resistance force.

Proceed as follows to reposition the compression spring correctly:

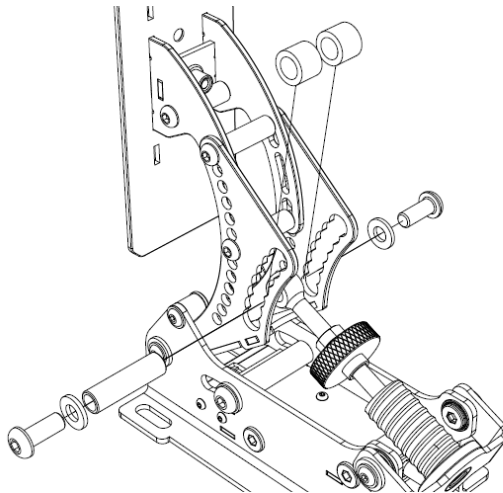

fig. 10 Changing the position of the compression spring

1. loosen the compression spring by unscrewing the knurled knob by hand so that it does not press against the pedal lever;
2. using H5 spanners, carefully unscrew the fastening screw, remove the second fastening screw together with the sliding sleeve and two positioning sleeves ;
3. move the eyebolt securing the spring to the desired height and screw it in the correct order of elements [Fig.10];
4. after completing the above changes, tighten the compression spring by tightening the knurled knob.

4.4 Compression spring adjustment with knurled knob

For precise adjustment of the spring resistance force, a knurled knob has been installed to let you to compress or loosen the spring, as a result of which you can freely manipulate the spring resistance force. This operation should be performed after point 4.3

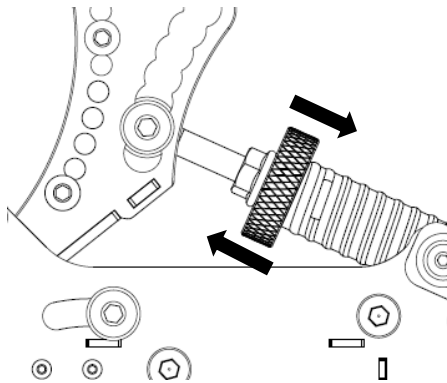

fig.11. Compression spring adjustment direction by knurled knob.

4.5 Changing the position of the pedal foot

The position of the foot can be changed up/down by selecting one of the three mounting holes spaced every 19 mm. Use an H3 Allen key for this purpose.

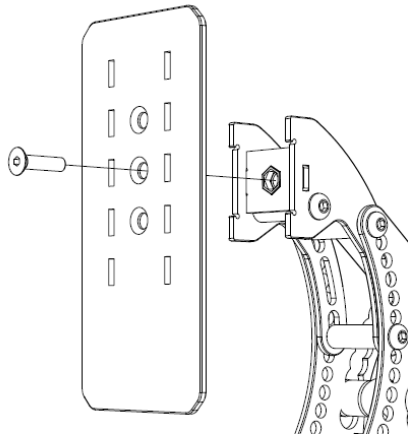

fig. 12. Changing the position of the foot.

Please be advised that all adjustable elements in the factory version have been set in the positions recommended by the manufacturer. When changing the factory version to individual settings, remember that due to different mounting positions, not all configurations can match. When changing settings, remember to always follow the manufacturer's recommendations.

4.6 Changing elastomers in the brake pedal

1. loosen the clamping unit by manually unscrewing the knurled knob so that it does not press against the pedal lever;
2. using H5 spanners, carefully unscrew the fastening screw, remove the second fastening screw together with the sliding sleeve and two positioning sleeves;

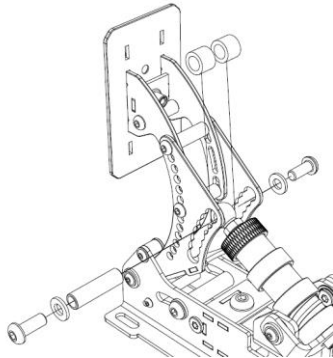

fig. 13. The first stage of changing

3. remove the eyebolt together with the pressing unit;

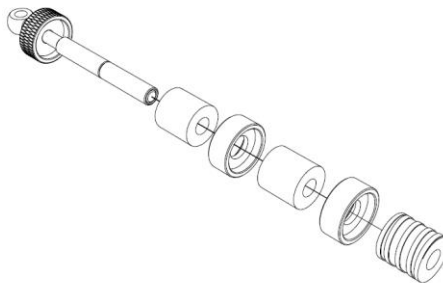

fig. 14. Elastomer clamping unit.

4. replace the assembly components with others included in the kit;
5. move the eyebolt securing the spring to the desired height and screw it in the correct order of the elements [fig.13];
6. after completing the above changes, tighten the clamping unit by tightening the knurled knob.

5. Pedal characteristics

The characteristics of the RAPTORS pedals have been developed on the basis of the relationship between the pressure force and the displacement of the pedal lever. This characteristic is individual for each of the available pedals. RAPTORS pedals, thanks to their construction, reflect the characteristics of real pedals, as illustrated in the charts below (fig. 15, 16, 17).

For each pedal, the zero point of the graph moves along the x-axis as the knurled knob is tightened, the pressing force for the zero point will change, for example, from 0 kg to 10 kg.

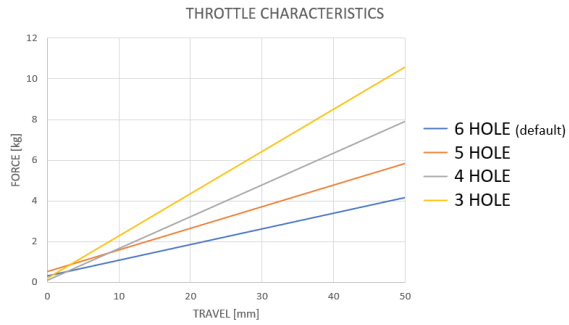

fig. 15. Characteristics of the accelerator pedal.

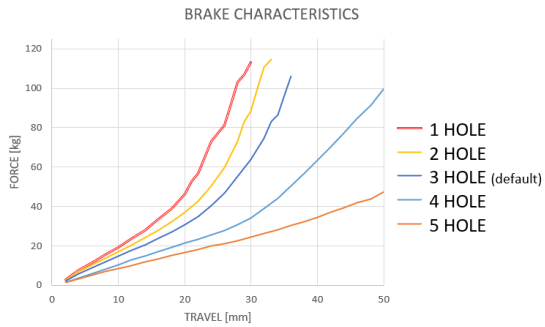

fig. 16. Characteristics of the brake pedal.

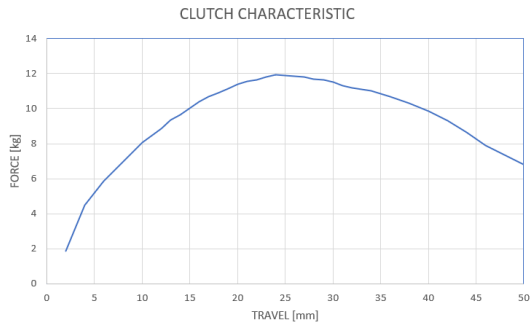

fig. 17. Characteristics of the clutch pedal.

6. Electronics connection

To start connecting the electronics, you need to prepare the accelerator pedal and other pedals you have. In the rear part, the accelerator pedal has two connection sockets (fig. 18). One is marked with letter B, the other with letter C. Connect the black brake pedal cable to socket B and the gray clutch pedal cable to socket C. After the pedals are properly connected to the controller's jacks, you can connect the USB cable to your computer.

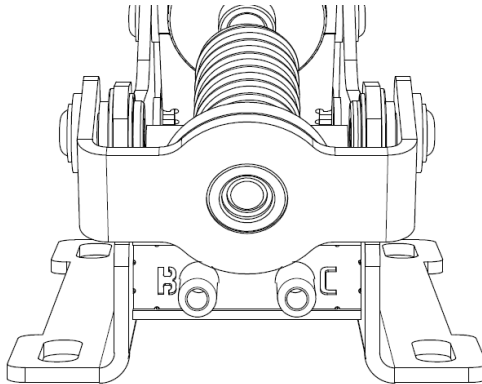

fig. 18. Electronics connection point.

NOTE!

Remember to connect individual pedals before connecting the USB cable (integrated with the accelerator pedal) to the computer.

When disconnecting the wires from the controller, grasp the plug housing, not the cable.

7. Calibration

Start the calibration by downloading the DView program, you can find on our website after scanning the QRcode:



Then run the program and select EDIT.

Tick **AW RAPTORS PEDALS** [Fig. 19].

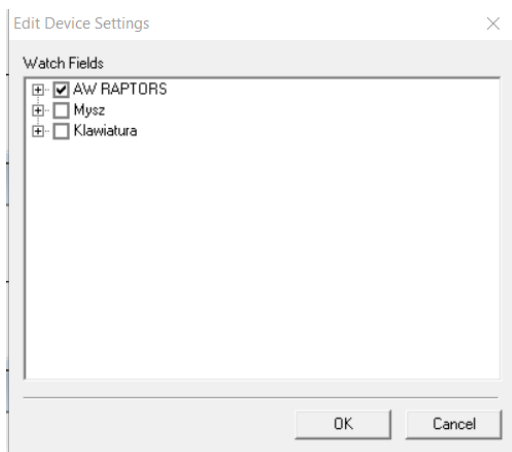

Fig. 19. Controller selection window

After selecting AW RAPTORS PEDALS on the axis with the selected pedal, right-click and select VIEW RAW DATA from the list. A red indicator and numerical and percentage values will appear [Fig. 20].

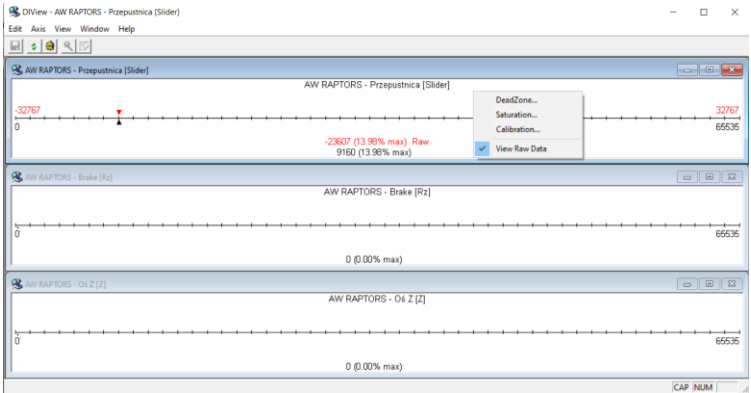

Fig. 20. VIEW RAW DATA window

Right click on the axis again and select CALIBRATION [Fig. 21].

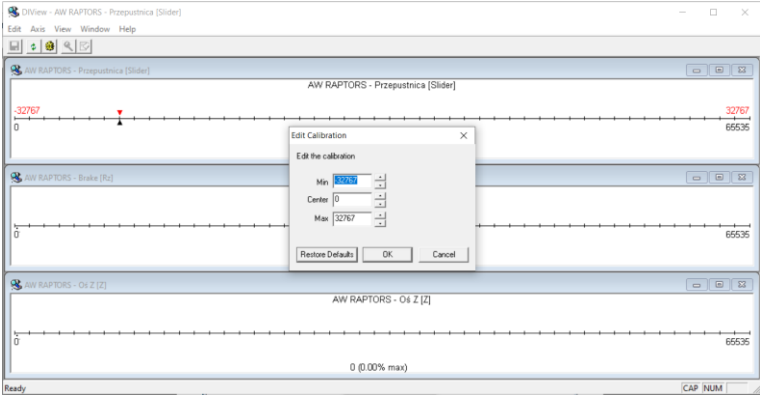

fig. 21. CALIBRATION window.

To properly calibrate the RAPTORS PEDALS you need to enter your min. value, enter the sum of the red value at the bottom of the axis, with the conventional value of 500. This value can be increased or decreased if necessary.

Example:

$$-23607 + 500 = -23107$$

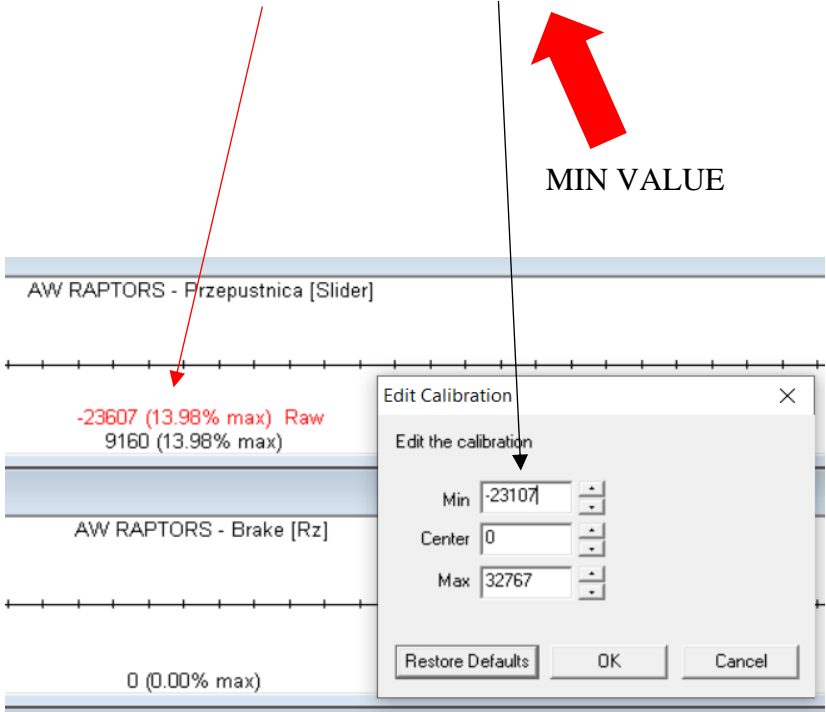

fig. 22. CALIBRATION window –MIN. value

By setting the Max. press the pedal to the selected position. After reaching the position, read the red value from the bottom of the calibration window and proceed as for the Min value.

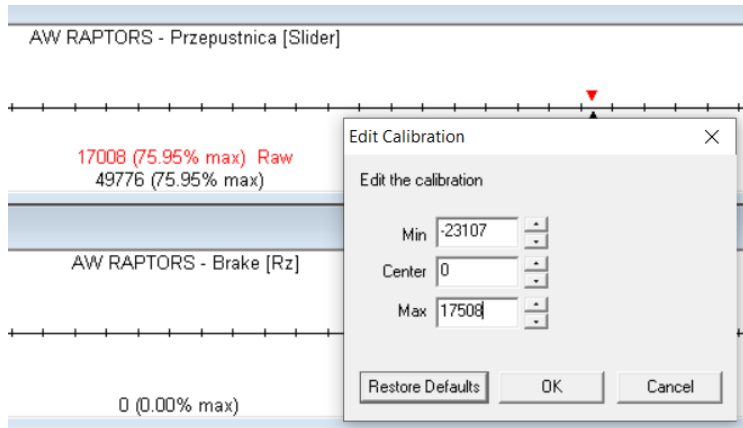

fig. 23. CALIBRATION window –MAX. value

We calculate the Center value as follows:

$$\frac{(\text{MIN} + \text{MAX})}{2} = \text{CENTER VALUE}$$

The Center value should be entered in the appropriate window and confirmed with the OK button.

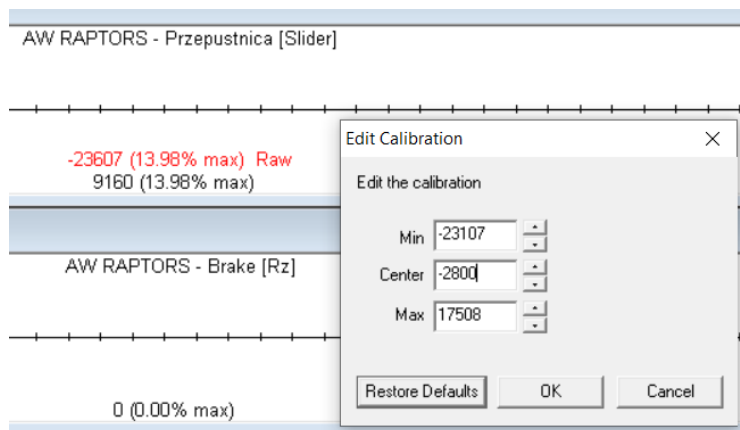

fig. 24. CALIBRATION window – Center value.

8. Maintenance

RAPTORS PEDALS are designed to minimize service effort. To keep your pedals in top condition for years to come, please refer to the guidelines in this section.

The most important protective and maintenance action is the systematic lubrication of the pedals in the most exploited places. The frequency depends to a large extent on the intensity of use. The basic symptom that indicates the need for maintenance is the characteristic creaking sound caused by friction. The recommended maintenance agent is lithium grease.

9. Environmental recommendations

Electronic and electrical devices must not be disposed of with other household waste. They should be recycled at specialized collection points for waste electronic and electrical equipment, in order to avoid negative impact on the environment and human health. Please contact your local authorities for information on the location of such outlets.

10. Warranty information

Another Way with its registered office in Bogusławki Małe 25C, 96-200 Rawa Mazowiecka guarantees that RAPTORS PEDALS product will be free from material/manufacturing/construction defects for a period of two (2) years from the moment of delivery of RAPTORS PEDALS to the customer.

For commercial pedal use, the term is one (1) year.

In the event of any symptoms that may indicate a defect in the product, immediately contact the manufacturer, they will specify the further procedure.

Under the specified warranty, a defective product will be repaired or replaced with a functional one, or the purchase price will be

refunded, provided that the product along with a copy of the invoice or receipt is delivered to the manufacturer. The decision related to the consideration of the complaint belongs to the Manufacturer.

This warranty does not apply when:

- ✓ the product has been modified on your own;
- ✓ changed, altered or damaged due to misuse or abuse;
- ✓ an accident was caused by the customer;
- ✓ there was negligence in use, normal wear and tear or for any other reason that is not solely due to a material or manufacturing defect;
- ✓ it was used for commercial use;
- ✓ there was non-compliance with the manufacturer's instructions;
- ✓ the product was resold.

NOTE

Remember, to submit a complaint, you must contact the place where the product was purchased.

Place for notes.....